

Analysis of a Steel Bridge Connected with Tunnel Considering Live Project Data Using SAP2000

Dolly Dewangan, Shubham Dashore, Dr. S. K. Jaiswal

Department of Civil Engineering, Bhilai Institute of Technology Durg, Chhattisgarh, India

Article Info

September-October-2022

Publication Issue :

Volume 6, Issue 5

Page Number : 78-90

Article History

Accepted : 08 Sep 2022

Published : 20 Sep 2022

ABSTRACT

Majority of the truss bridges in India and abroad are either structurally deficient and/or functionally obsolete. There is a desperate need to enhance the performance of these existing bridges by an appropriate technique which should be economical and with minimum disturbance to the traffic. The aim of the present analytical work is to know the effect of Pre-stressing on the member forces, deflections and total weight of steel of a statically determinate three types of trusses such as Pratt type or Warren truss..Pre-stressing technique has been adopted to upgrade the performance of the truss. The truss is pre-stressed with high tensile steel cable and the profile of the cable is straight. The truss is analysed for member forces and deflections using SAP 2000 Software. From the obtained analytical results, it is seen that there is a noticeable improvement in the performance of the structure. Member forces have been reduced significantly in the entire truss members and there is a reduction in deflection at the centre and material requirement after pre-stressing.

Keywords : Bridges, Truss, Pre-stressing, Cable, Member forces, Deflections and SAP 2000.

I. INTRODUCTION

Bridge is a structure which permits the section of people on foot or vehicles worked over any hindrance or water body. There are several bridge designs that serve an appropriate purpose. Depending on the behavior of bridge.

There are various types of bridges

1. Timber bridge
2. Concrete bridge
3. Steel bridge
4. Composite bridge

Bridge has mainly two sections the superstructure and the substructure. The superstructure has deck slab, I-Girder and shear connectors though substructure has of the footer, stem and the cap. Composite construction consists of two unique materials which are strongly bound to form a solitary unit.

“Composite” implies that the concrete portion of the deck is associated with the steel portion of the bridge by shear connectors. Shear connectors are fundamentally fixed on steel beams and then they are embodied in the concrete slab. Shear connectors can be associated by welding, or utilizing nut and bolts.A steel beam which is assembled composite by utilizing

the shear connectors and concrete which is more strong and stiff as compared to beam.

Steel Bridge

Steel bridges are widely used around the world in different structural forms with different span length, such as highway bridges, railway bridges, and footbridges. The main advantages of structural steel over other construction materials are its strength, ductility, easy fabrication, and rapid construction. It has a much higher strength in both tension and compression than concrete, and relatively good strength to cost ratio and stiffness to weight ratio. Steel is a versatile and effective material that provides efficient and sustainable solutions for bridge construction, particularly for long span bridges or bridges requiring enhanced seismic performance.

Amongst bridge materials steel has the highest and most favorable strength qualities, and it is therefore suitable for the most daring bridges with the longest spans. Normal building steel has compressive and tensile strengths of 370 N/sq mm, about ten times the compressive strength of a medium concrete and a hundred times its tensile strength. A special merit of steel is its ductility due to which it deforms considerably before it breaks, because it begins to yield above a certain stress level.

Properties of steel bridges include:

- Compared to concrete bridges, the self-weight is relatively light and long-span bridges can be constructed.
- It is possible to manufacture durable and homogeneous quality materials in large quantities, and quality assurance is possible because the elements are manufactured in controlled environments.
- Design and construction of stunning bridges to match the surrounding landscape is possible.
- Easy to inspect for deterioration or damage; easy to repair/reinforce or dismantle; materials are recyclable.



Fig 1. Steel Bridge

II. Literature Review

Nitin Indulkar et.al (2022) research paper investigate the factors that causes the seismic forces in the system. A simplified analysis methodology is put forward based on IRC SP 114; 2018. It is applicable for seismic design of bridges with a design service life of 100 years, considering Design Basis Earthquake (DBE). It has covered the seismic map and spectral acceleration graphs as specified in IS: 1893-Part-I- 2016. It also adopts the method prescribed for evaluation of liquefaction possibility, as specified in IS: 1893-Part-I-2016. For the evaluation of seismic forces, Elastic Seismic Acceleration method, Elastic Response Spectrum method and Linear Time History method are specified. The IRC Guidelines describe the various types of special investigations to be carried out for bridges to be constructed in near field zones, skew, and curved bridges and so on. For loads and load combinations, IRC 6-2017 provides the guidelines and specifications. The objective of this code is to provide common procedure for design of bridges. It deals with the various loads such as vehicular loads, braking forces, wind load, water current forces and their combinations. Results stated that the maximum resultant force in zone III increased by 112% in Zone V and the maximum and minimum resultant moment in zone III was increased by 123.6% and 128.8% respectively in Zone V.

Pratik Soni et.al (2022) research paper investigated three types of sections (i.e. Warren truss, Pratt truss

and Howe truss). Two span lengths was analyzed, 40 m and 80 m, with a height of 7 m and a width of 6 m, and was simply supported at the ends. The suitable locomotive loading for broad gauge (1.676 metre wide) railway track was considered as per IRS Bridge regulation while the railway bridge was examined. These bridges were analysed for comparing node displacement, beam forces, and response at the supports due to movement load of locomotives with seismic zone 5 being considered. STAAD.Pro V8i was used to conduct the analysis on parameters of node displacements, beam end forces, and support responses were used to interpret the results.

Results stated that for a 40-meter-long truss bridge, the Warren truss exhibits less node displacement and support response than the Pratt and Howe trusses. Overall, one can claim that the Warren truss is the finest piece of truss for a 40- meter span truss bridge. The Pratt truss or Howe truss may be utilised as the superstructure for an 80 metre span bridge with no alteration in member cross-section, while the Warren truss behaves the worst of the three types of truss for the same.

A Jayaraman et.al (2021) research paper aimed to resist the seismic force/ vibration force in railway steel truss bridges using splice connection. Using the

Warren type of railway truss bridges Analysis and designed by Indian standard railway code (IRC) and IS 800 -2007. The connection of the railway truss bridge is bolted with splice connection. Same cross sectional area has been carried for both theoretical and experimental investigation.

Results stated that the splice connection has high load carrying capacity, low deflection and high level seismic resistance. The members designed with splices show greater reduction in the structural weight. Experimental evaluation shows increase in the load carrying capacity and decrease in the deflection while using members with splices by 24% Splice connection best seismic performance compared to the other type of connection.

Objectives of the research

1. To determine the effect of vehicular loading over steel bridge connected with tunnel.
2. To study utilization of analysis tool SAP2000 as per I.R.C. guidelines for bridge analysis.
3. To determine the most suitable type of steel bridge in comparison with tunnel section.
4. Analysis of a steel bridge considering lateral load using I.S. specified sections.

III. METHODOLOGY

This section presented the steps undertaken while modelling and analysis of the two cases using analytical application SAP2000. The materials and sections will be specified and loading conditions will be defined to generate the optimised results.

the primary steps which will be followed in the research work are stated below:

Step 1: In the first step we will review the literature to justify the aims and objectives of the study.

Step 2: Modelling of the Frame using SAP2000 as per the cases considered in this study.

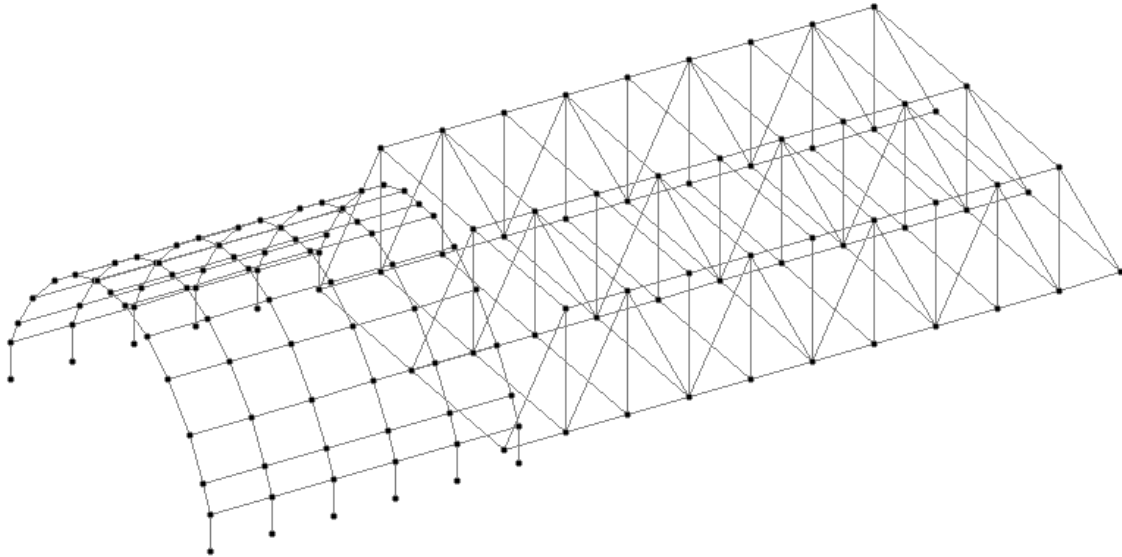

Fig 2 Model of Bridge with Tunnel

Step 3: In this step, assigned sectional data and material description and Path Data

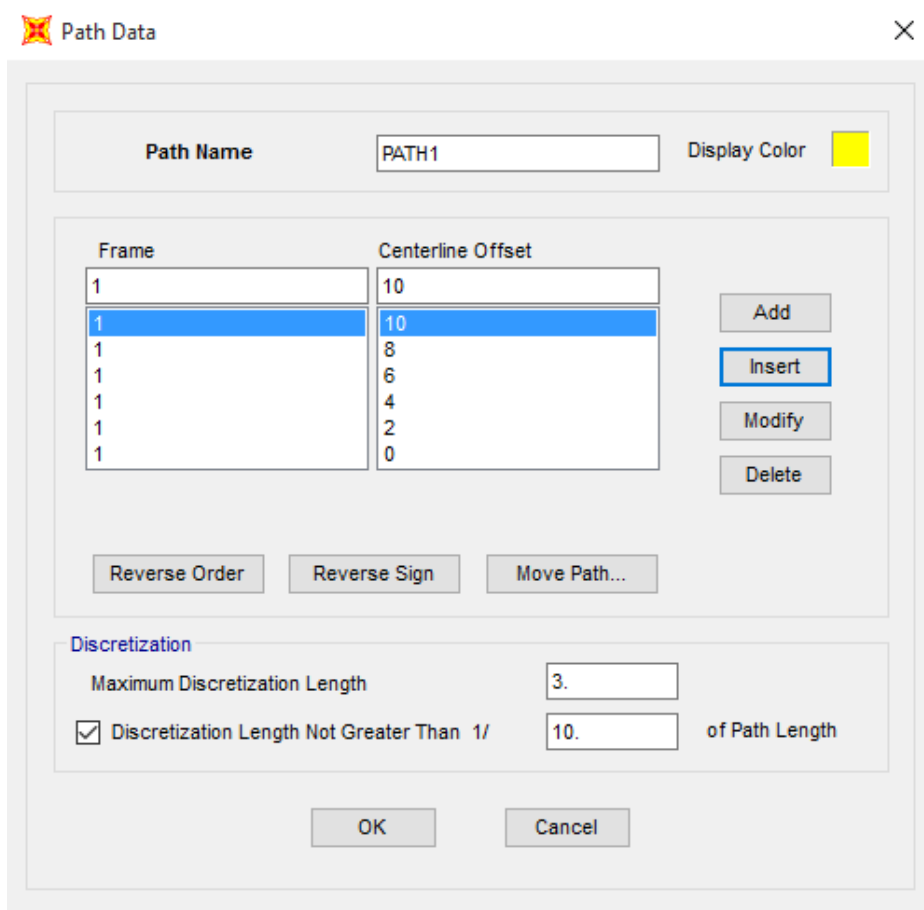

Fig 3 Path Data

Step 4: In this step assigned support condition to the models.

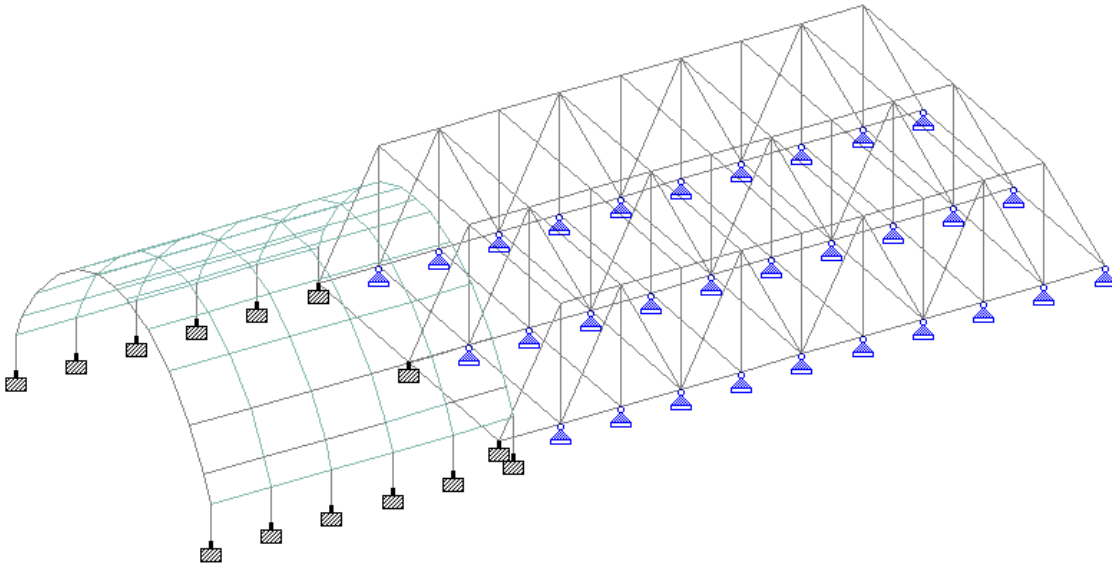

Fig 4 Defining Support Condition

Step 5: In this step we will assign loading condition as per I.R.C. loading condition.

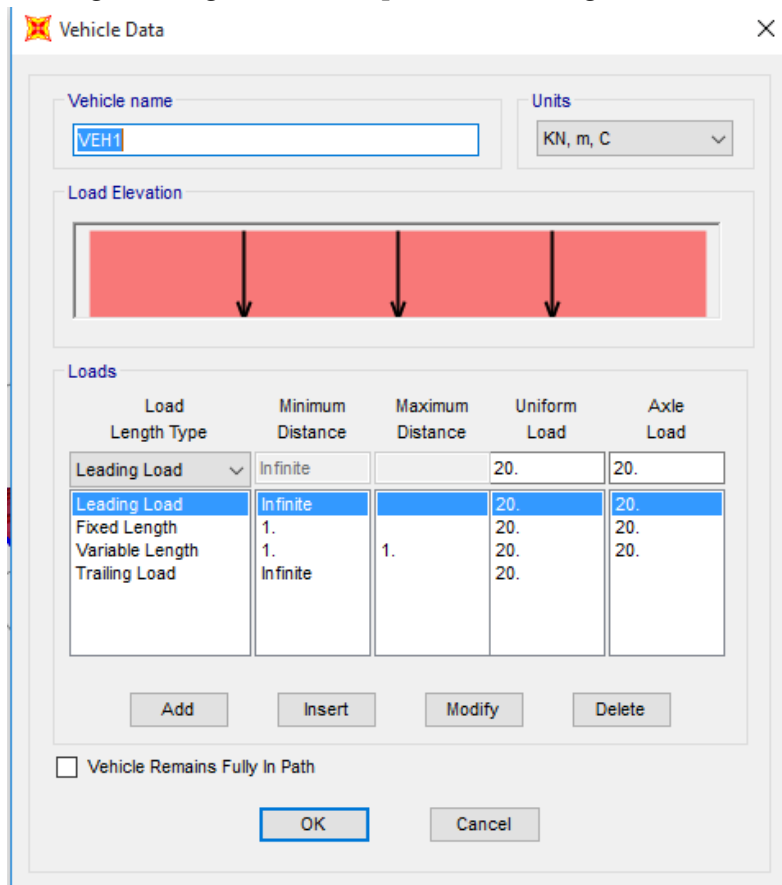

Fig 5 Defining Load Condition as per IRC Loading

Step 6: In this step assign loading condition and seismic data

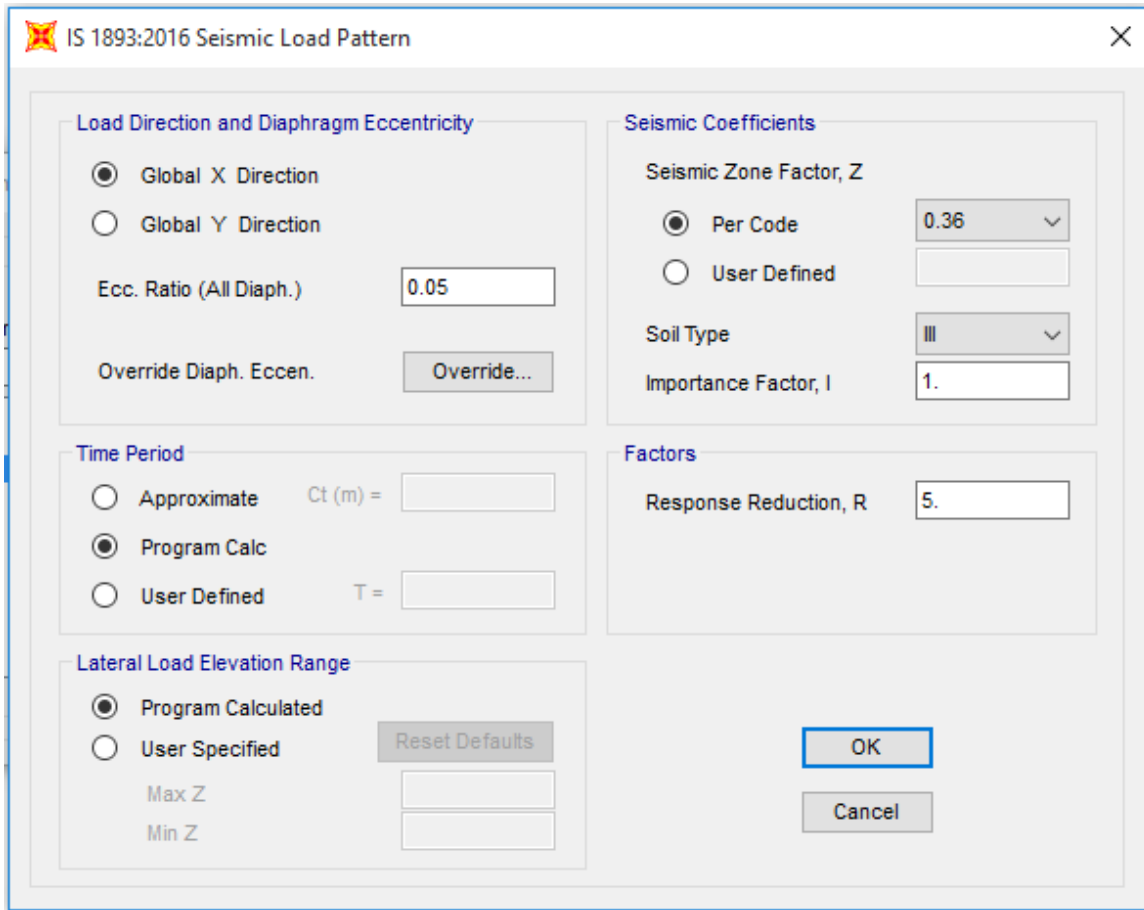

Fig 6 Assigning Loading condition as per Seismic data

Step 7: Analyzing the output and comparing the results.

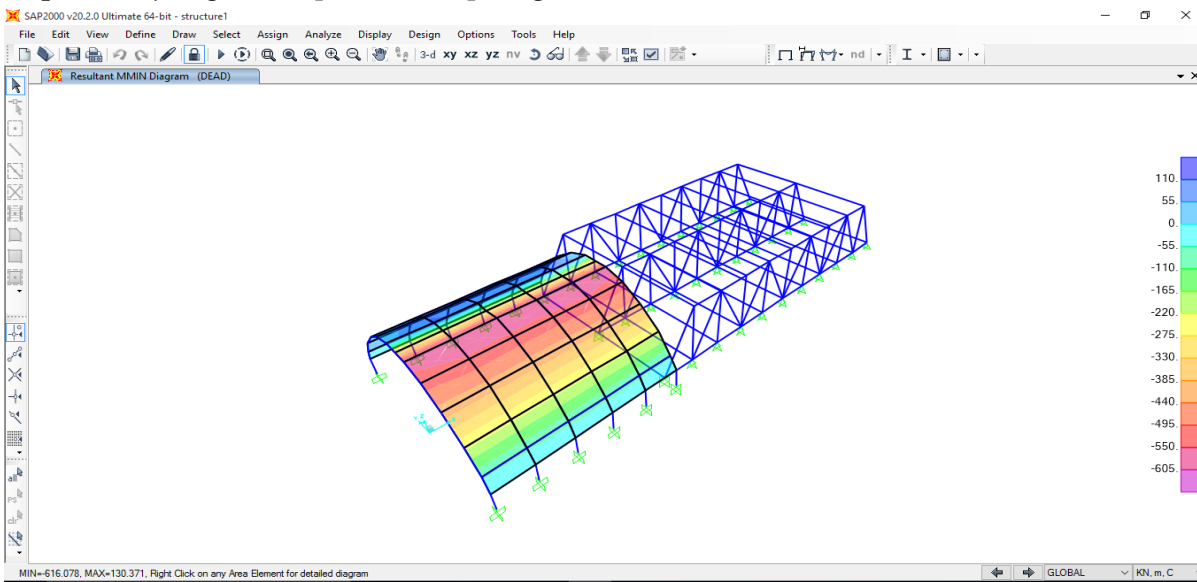

Fig 7 Stress Analysis of the Model

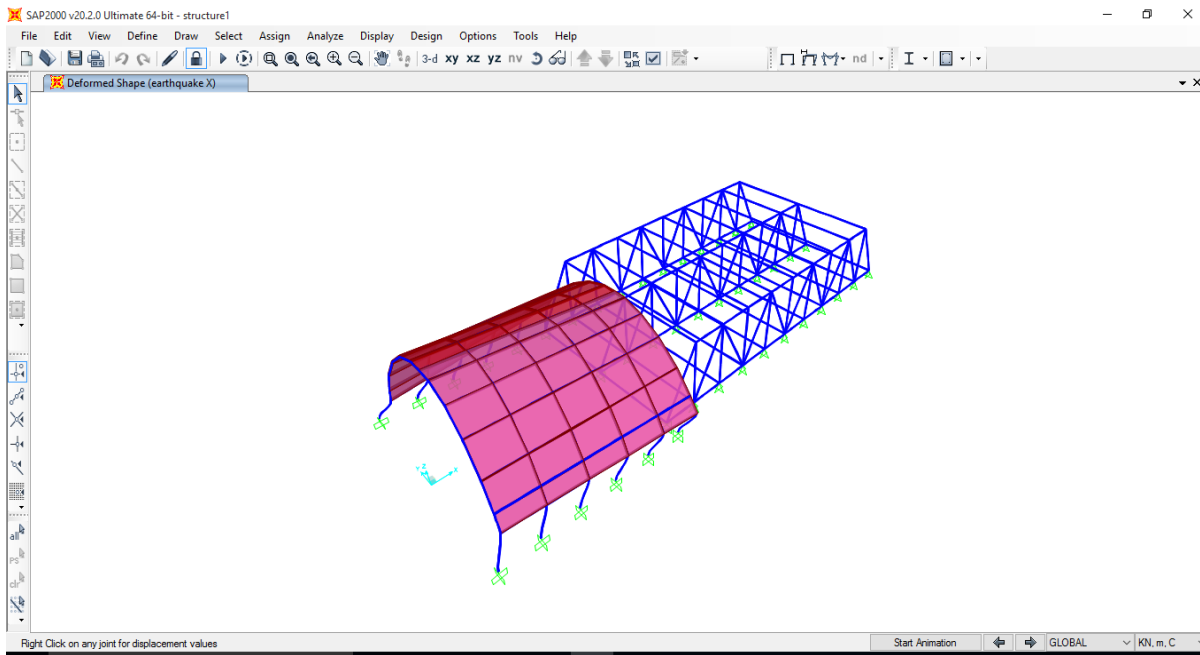

Fig 9 Bridge with Pratt Truss

Case II- Bridge with Warren Truss

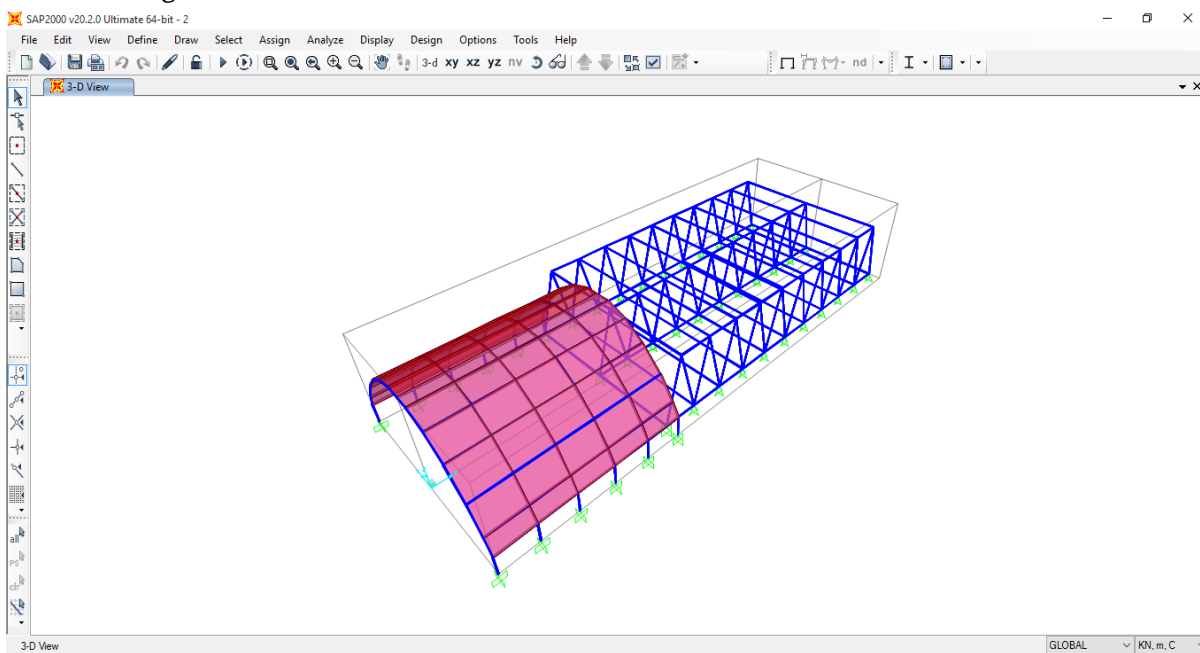

Fig 10 Bridge with Warren Truss

Geometrical Description of the Structure

Table 1 Geometrical Description

Dimension of the model	
Length	450 m
Height	20 m

Steel Section	As per Steel Table Indian Section
Connection	Bolted
Material	Mild Steel
Haunch	100 x 100 mm

Result & Discussion:

Shear Force

Table 2 Shear Force in kN

Maximum Shear Force in kN	
Bridge with Warren Truss	Bridge with Pratt Truss
382.256	466.402

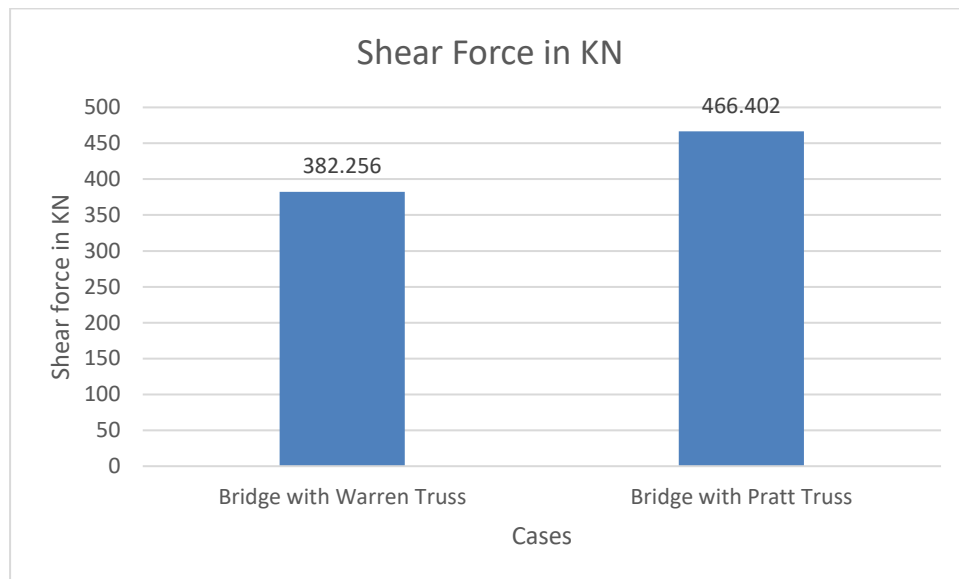

Discussion: A shear force is a force applied along the surface, in opposition to an offset force acting in the opposite direction. This results in a shear strain. In simple terms, one part of the surface is pushed in one direction, while another part of the surface is pushed in the opposite direction. Shear force was maximum in Bridge with Pratt Truss when compared to bridge with Warren truss providing to be 12% on the higher side.

Maximum Deflection in mm

Table 3 Maximum Deflection in mm

Maximum Deflection in mm	
Bridge with Warren Truss	Bridge with Pratt Truss
690.141	598.402

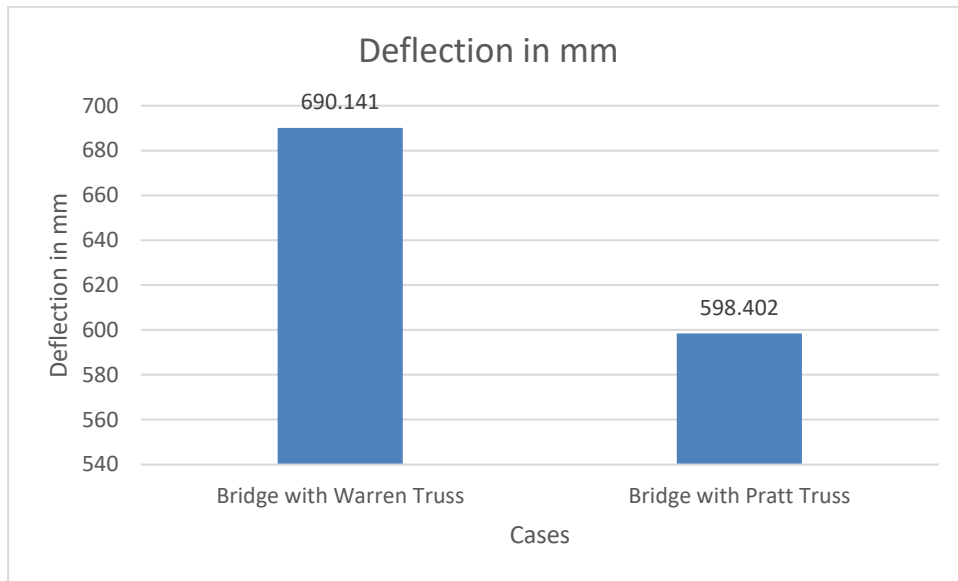

Support Reaction in kN

Table 4 Support Reaction in kN

Support Reaction in kN	
Bridge with Warren Truss	Bridge with Pratt Truss
3912.869	4179.519

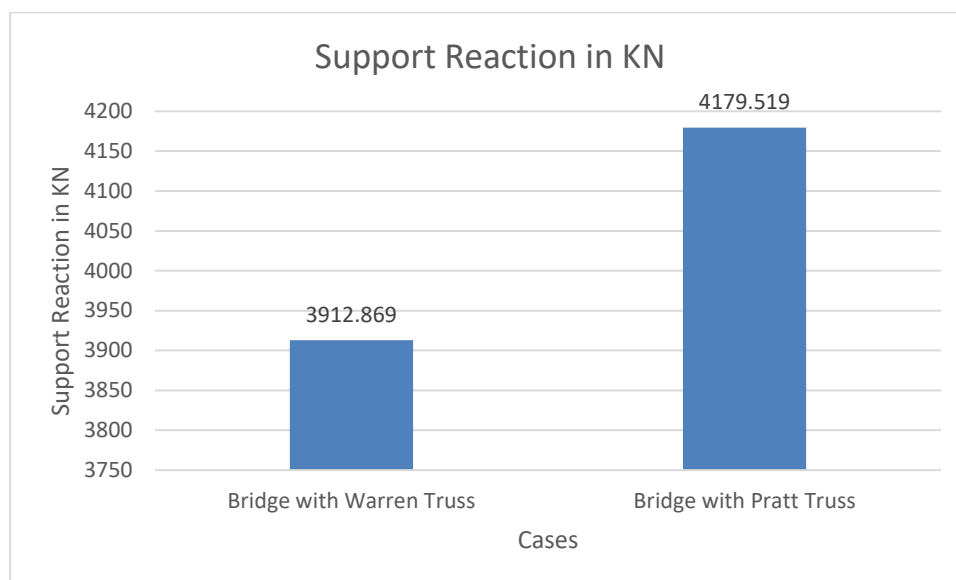

Discussion: A support reaction can be a force resulting in a support or a resulting restraining end moment, which results due to a prevented possibility to move. In the case of structural systems, support reactions are in equilibrium with the external forces acting on the structure. Support reaction was 3.9 % on higher side in case of bridge with Pratt Truss when compared to Bridge with Warren Truss

IV. CONCLSION

This project discussed the analysis and design of steel truss bridge connected to tunnel, the bridge is 450m long and 20 m high, the spaces between the trusses in the roof are various, from the beginning by leaving space that equal 0.5 m, divided all spaces in 10 segment the length of each one equal 7m.

Shear Force

A shear force is a force applied along the surface, in opposition to an offset force acting in the opposite direction. This results in a shear strain. In simple terms, one part of the surface is pushed in one direction, while another part of the surface is pushed in the opposite direction. Shear force was maximum in Bridge with Pratt Truss when compared to bridge

with Warren truss providing to be 12% on the higher side. Maximum shear force value is for Pratt truss bridge which is 485.763 KN connected with tunnel.

Maximum Deflection

corresponding to 75% of peak load and post-peak deflection at 80% of peak load, respectively. Maximum deflection was 9% higher in case of bridge with Pratt Truss when compared to bridge with warren truss.

Torsional Values

In the field of solid mechanics, torsion is the twisting of an object due to an applied torque. Torsion is expressed in either the pascal (Pa), an SI unit for newtons per square metre, or in pounds per square inch (psi) while torque is expressed in newton metres (N · m) or foot-pound force (ft.). Torsional values were 6.7% higher in bridge with Pratt Truss when compared to bridge with Warren truss. Torsional value for pratt truss bridge is 30% more than pratt truss & 22% more than warren truss bridge.

Support Reaction

A support reaction can be a force resulting in a support or a resulting restraining end moment, which results due to a prevented possibility to move. In the

case of structural systems, support reactions are in equilibrium with the external forces acting on the structure. Support reaction was 3.9 % on higher side in case of bridge with Pratt Truss when compared to Bridge with Warren Truss. Maximum support reaction is 4946.319 KN for pratt truss bridge.

V. REFERENCES

- [1]. Heena Dewangan and Kaushik Majumdar, [COMPARISON OF DIFFERENT TYPES OF TRUSSES IN VIBRATION ANALYSIS USING STAAD PRO], International Journal of Engineering Sciences & Research Technology, June, 2018, ISSN: 2277-9655.
- [2]. Kuihua Mei, Wangwang Fu and Jufeng Su, [Seismic Analysis of Hybrid System Bridge of Multi-Span Continuous Girder and Arches], E3S Web of Conferences 165, 04032 (2020).
- [3]. Purevdorj Sosorburam and Eiki Yamaguchi, [Seismic Retrofit of Steel Truss Bridge Using Buckling Restrained Damper], Appl. Sci. 2019, 9, 2791.
- [4]. Li Yuanming and Zhou Zhixiang, [Earthquake Performance Analysis of Steel Truss-Concrete Continuous Rigid Frame Bridge], Int. Journal of Engineering Research and Applications, ISSN : 2248-9622, Vol. 4, Issue 4(Version 3), April 2014, pp.24-30.
- [5]. Mohamed Ghannam, Nabil S. Mahmoud, Ahmed Badr and Fikry A. Salem, [Numerical Analysis for Strengthening Steel Trusses using Post Tensioned Cables], 2017 Global Journals Inc.
- [6]. Daihai Chen, Wenzhe Wang, Zheng Li, Zhenqi Xu and Fengrui Ma, [Comparative analysis of seismic performance of 122-meter long concrete-filled steel tube arched chord truss bridge before and after reinforcement], JOURNAL OF ASIAN ARCHITECTURE AND BUILDING ENGINEERING 2020, VOL. 19, NO. 2, 90–102.
- [7]. Ebrahim Amirhormozakia, Gokhan Pekcana and Ahmad Itania, [Analytical Modeling of Horizontally Curved Steel Girder Highway Bridges for Seismic Analysis], Journal of Earthquake Engineering, 19:220–248, 2015.
- [8]. Mohd Waseem and Mohammad Saleem, [Seismic Analysis of Box Girder Bridge using CSiBridge Software], International Journal of Management, IT & Engineering Vol. 9 Issue 5, May 2019, ISSN: 2249-0558 Impact Factor: 7.119.
- [9]. Nitin Indulkar, A.N. Humnabad and Dr. Navnath V. Khadake, [Comparative Study of Seismic analysis of Bridge Substructure in different Seismic Zones as per IRC Guidelines], International Journal for Research in Applied Science & Engineering Technology (IJRASET) ISSN: 2321-9653; IC Value: 45.98; SJ Impact Factor: 7.538 Volume 10 Issue V May 2022.
- [10]. Yongjian Chen, Honglie Sun and Zhenfa Feng, [Study on Seismic Isolation of Long Span Double Deck Steel Truss Continuous Girder Bridge], Appl. Sci. 2022, 12, 2567.
- [11]. Mohamed Abdel-Basset Abdo, [ANALYSIS OF STEEL BRIDGES WITH RECTANGULAR WEBOPENINGS: FINITE ELEMENT INVESTIGATION], Journal of Engineering Sciences, Assiut University, Vol. 38, No. 1, pp. 1-17, January 2010.
- [12]. E. Bhargavi and G.V.Rama Rao, [Comparative Parametric Study of Steel Bridge Trusses by Applying External Prestressing], International Journal of Engineering Technology, Management and Applied Sciences, July 2015, Volume 3, Issue 7, ISSN 2349-4476.
- [13]. Jayakrishnan. T J and Lekshmi Priya. R, [Analysis of Seismic Behaviour of a Composite Bridge using ANSYS], International Journal of Engineering Research & Technology (IJERT), ISSN: 2278-0181, Vol. 6 Issue 05, May - 2017.

- [14]. Baokui Chen, Yujie Du, Yan Shi and Li Fan, [Seismic Analysis of Isolated Continuous Bridge considering Influence of Seawater and Site Condition], Hindawi Shock and Vibration Volume 2021, Article ID 7599715, 17 pages.
- [15]. E. Tapia-Hernández, T. Perea, K.E. Barth and M.G. Barker, [SEISMIC INFLUENCE ON THE SHORT SPAN STEEL BRIDGE DESIGN], Tenth U.S. National Conference on Earthquake Engineering Frontiers of Earthquake Engineering July 21-25, 2014.
- [16]. Mehmet F. Yılmaz and Barlas Ö. Çağlayan, [Seismic assessment of a multi-span steel railway bridge in Turkey based on nonlinear time history], Nat. Hazards Earth Syst. Sci., 18, 231–240, 2018.

Cite this article as :

Dolly Dewangan, Shubham Dashore, Dr. S. K. Jaiswal, "Analysis of a Steel Bridge Connected with Tunnel Considering Live Project Data Using SAP2000", International Journal of Scientific Research in Civil Engineering (IJSRCE), ISSN : 2456-6667, Volume 6 Issue 5, pp. 78-90, September-October 2022.

URL : <https://ijsrce.com/IJSRCE226511>