

Analysis of a Cement Storage bin Considering Lateral Forces using Staad.pro

Mukesh Kumar¹, Rachana M Bajaj², Kapil Soni³

¹P. G. Scholar, ²Assistant Professor, ³Assistant Professor & H.O.D
Department of Civil Engineering, RNTU, Bhopal, Madhya Pradesh, India

ABSTRACT

Article Info

Volume 4, Issue 4

Page Number: 91-96

Publication Issue :

July-August-2020

Article History

Accepted : 01 Aug 2020

Published : 10 Aug 2020

Concrete has the ability to conform to any desired shape and also it's economical. Concrete proves to be a very useful material as it offers all the flexibilities in designing and construction of silos and bunkers which are required by any industry and foremost being in the economical limits.

Importance of these storage structures has attracted the attention of many researchers worldwide to propose different load calculation methods and design considerations. ACI 1997 is the only available guidelines, for the design of silo and bunkers. In addition to it, different researchers proposed different methods to compute the loads of moving and loading material inside the silos and bunkers.

In this study we have comparing two bunkers considering same dimension, capacity and loading condition. In these two cases we are considering concrete and steel material to prepare a comparative study to determine the most suitable type of bunker. The designing and analysis of the structure is done using analytical application Staad.Pro V8i. and results were compared on parameters namely Stress analysis, Support reaction, Deflection Axial Force and Shear Force.

Keywords : RCC bunker, Steel bunker, Support Reaction, Stress Analysis, Deflection, Axial Force and Shear Force.

I. INTRODUCTION

Bunkers are mainly employed for storage of underground dwellings. These are mainly related to emergency conditions during wars. The main two characteristics that make a bin to act as a bunker is based on the Depth (H) and Angle of rupture.

These are characterized as shallow structures. The angle of rupture of the material in case of bunkers, will meet the horizontal surface at the top of the bin, before it touches the opposite side walls of the structure. Bunkers may be circular or rectangular (or square) in plan.

In this study we are comparing two bunkers considering same dimension, capacity and loading

condition. In these two cases we are considering concrete and steel material to prepare a comparative study to determine the most suitable type of bunker. In this study we are comparing two bunkers considering same dimension, capacity and loading condition. In these two cases we are considering concrete and steel material to prepare a comparative study to determine the most suitable type of bunker.

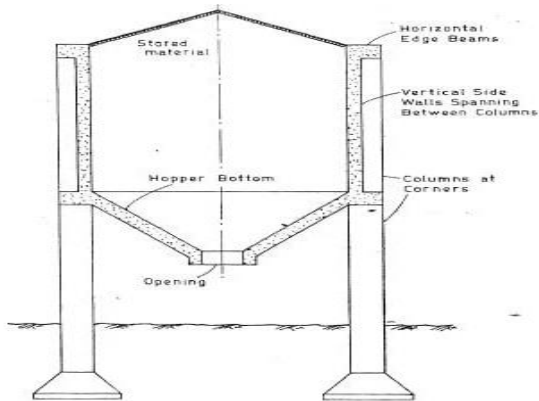

Fig 1 : Specific diagram of bunker

Objectives of the Study

The main objective are

- To determine the effect material type in bunker
- To determine the lateral stability of the structure under seismic loading as per Indian Provision I.S. 1893-I:2016.
- To determine the utilization of analysis tool staad.pro for modelling and analysis of a tall structure.
- To determine the cost effectiveness of concrete and steel bunker.

II. LITERATURE REVIEW

Sagar R. Aambat et. al. (2018) the examination featured the impact of stature to parallel measurement ratio on the dynamic conduct of reinforced concrete cement (RCC) round silo. The different load intensities and structural boundary were computed utilizing Janssen's hypothesis according to IS: 4995 (Part I and Part II): 1974.

Investigation of the silo was directed utilizing Response Spectrum Method and Wind Analysis. The considered silo was exposed to various seismic zone, for example, Zone-III and Zone-V according to IS: 1893 (Part-I):2016 and wind investigation was completed according to IS: 875 (Part-III): 2015. The circular structure was displayed and analyzed utilizing application Staad.Pro.

Results expressed that base shear expanded with H/D proportion increment and for the higher seismic zone. Sidelong uprooting expanded with H/D proportion increments. As H/D proportion expands the impact of wind load shows up in basic load blend for Zone-III while for Zone-V tremor load be a piece of a critical load combination.

Krishna T. Kharjule and Minakshi B. Jagtap (2015)

Four models were utilized to investigate elevated R.C.C. silo with and without shear divider and steel silo with and without shear divider board use M20 and Fe 500. R.C.C. Silo and steel silo in RSM technique with shear divider relocation of the structure was decreased in contrast with without shear divider. Because of utilizing a shear divider timespan of structures diminishes.

Suvarna Dilip Deshmukh and Rathod S. T. (2013) the industrial silo was dissected and planned by the Indian standards (IS 4995) and by alluding Euro code (EN 1998 - 4: 1999 and EN 1991-4: 2006) and ACI code (ACI 313). In this examination, a 450 cum limit level base silo plan and investigation.

Conclusion stated that pressure estimation given as ACI code was seen as more traditionalist side than different codes of training. The fortification was found to shifting along with the profundity of the divider and saw as additional on the centre part of the divider. Silo plan and development depended on quality structure strategy.

III. METHODOLOGY

Step 1 Modelling of the Structure using Staad.Pro v8i as per the geometry

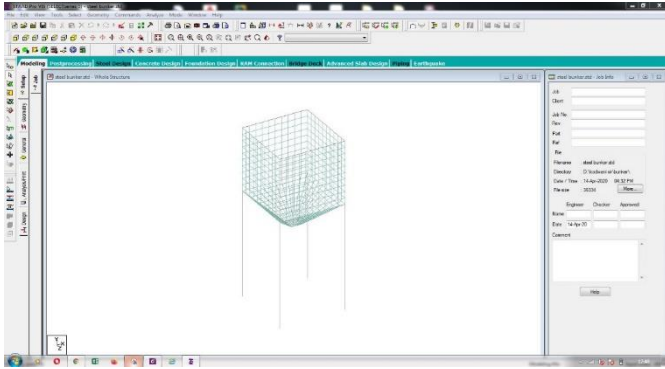

Fig 2: Modelling of structure

Step 2 Designing the Structure using nodes and assigning properties on plate thickness and ISMB 200 steel.

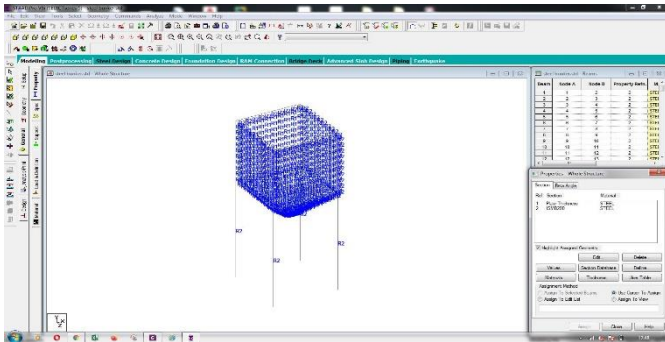

Fig 3 Assigning Steel Properties as per IS 2062 (2011)

Step 3 Assigning Support conditions at the bottom of the legs of structure.

Step 4 Assigning Seismic Load as per IS 1893-2016

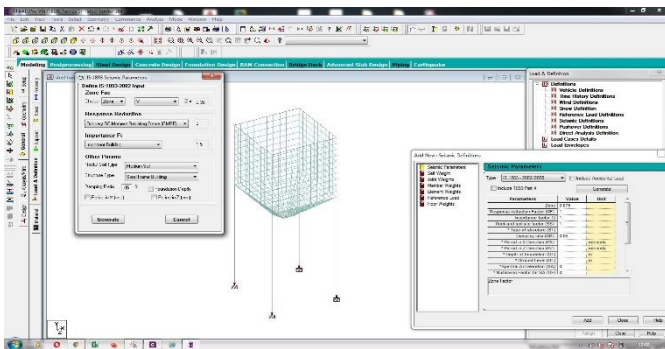
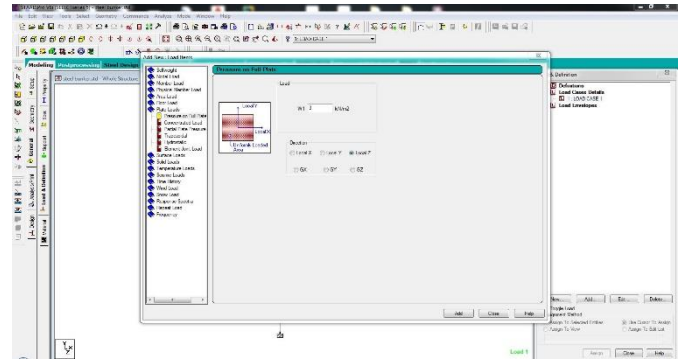

Fig 4 Assigning Loading Condition Seismic Load

Step 5 Assigning Dry weight of cement material



Step 6 Valuating Support Condition

Step 7 Extracting Structure Force Generation

Step 8 Stress Valuation on RCC Bunker and Steel Bunker

Step 9 Analysis of structure using analysis tool MIDAS gen

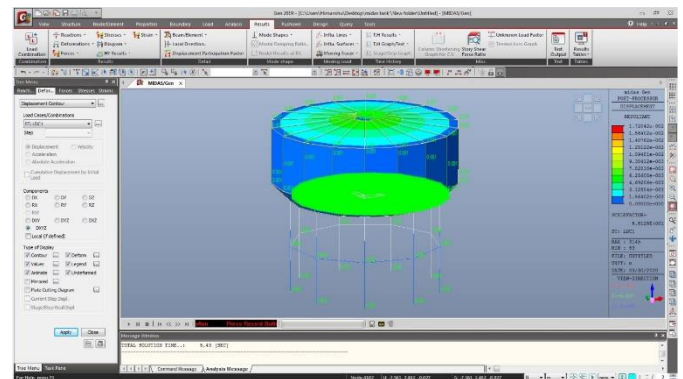

Fig 6 Analysis Results

Table 1: Geometrical details

Description	Values
Storage Type	Bunker
Length	3 m
Width	3 m
Height	3.0 m
Divisions in X direction	10

Divisions in Z direction	10	Thickness of R.C.C./Steel Plate	125 mm
Size of beam	250 x 350 mm		
Size of column	350 x 350 mm		

IV. Analysis Results

Table 2 : Stress Analysis at steel

Forces on steel side plates						
Section	Axial Force kN	Shear-Y kN	Shear-Z kN	Torsion kNm	Moment-Y kNm	Moment-Z kNm
0	55.45	6.21	8.75	0	1.45	0
1	58.73	4.8	9.57	0	3.21	1.09
5	62.01	5.31	10.39	0	4.97	4.32
10	65.29	7.45	11.21	0	6.73	7.55
15	68.57	9.59	12.03	0	8.49	10.78
20	71.85	11.73	12.85	0	10.25	14.01

Table 3 : Stress Analysis at RCC

Forces on R.C.C Plates						
Section	Axial Force kN	Shear-Y kN	Shear-Z kN	Torsion kNm	Moment-Y kNm	Moment-Z kNm
0	49.68	4.03	7.55	0	0	0
1	51.87	4.123	8.21	0	2.54	0
5	54.06	5.53	8.87	0	4.62	2.34
10	56.25	6.937	9.53	0	6.7	2.69
15	58.44	8.344	12.65	0	8.78	3.04
20	60.63	9.751	13.21	0	10.86	3.39

Support Reaction:

Table 4: Support Reaction

Support reaction y direction	
R.C.C. Bunker	Steel Bunker
115.34	131.05

Table 5: Deflection

Maximum Deflection in mm	
R.C.C. Bunker	Steel Bunker
1.8	3.37

V. CONCLUSION

The R.C.C. structure in comparison to steel structure system has not only improved displacement capacity of bin, but also the horizontal solidness and quality limit of the structures by increasing its shear capacity.

Following observations are in observed as follows:

- In R.C.C. material structure we observed that support reaction value decreases by 11.8% which shows stability of the structure in distributing load to the soil.
- Here it is observed that R.C.C. bin resisting the deflection of the structure generating due to lateral load by 46.6 % which is very important aspect for safety.
- In terms of forces it is observed that unbalanced forces decreases from 5.6 KN to 3.21 KN which shows structure stability and stiffness.

Summary:

Finally we can conclude that R.C.C. bunker system may be used in place of steel bunker as it increases the stability of the structure, minimizes displacement forces and support reaction. It also does not get effected much by the atmosphere and environmental aspects in comparison to steel structure.

VI. REFERENCES

[1]. Sagar r. Aambat, sunil m. Rangari and priyanka a. Jadhav, [effect of height to lateral dimension ratio on dynamic behaviour of rcc circular silo], international journal of engineering science invention (ijesi), volume 7 issue 6 ver i || june 2018 || pp 62-68.

[2]. Krishna t. Kharjule and minakshi b. Jagtap, [seismic analysis of r.c.c. and steel silos], international journal of computational engineering research (ijcer), issn (e): 2250 – 3005 || volume, 05 || issue, 07 || july – 2015.

[3]. Vivek subhashrao wath, p p saklecha and r s kedar, [design and comparison of types of silo in koradi power plant], international journal of engineering research & technology (ijert) issn: 2278-0181, ic-quest - 2016 conference proceedings, special issue – 2016.

[4]. Suvarna dilip deshमुख and rathod s. T., [comparison of design & seismic behavior of rcc silo], international journal of science and research (ijsr), index copernicus value (2013): 6.14 | impact factor (2013): 4.438.

[5]. Rini riyansi.e and abida justus, [comparative study of silo supporting structure using rcc & steel], international journal of advanced research in basic engineering sciences and technology (ijarbest), issn(online) : 2456-5717, vol. 3, special issue 35, april 2017.

[6]. Dharani.k and jeyakumar.d, [analysis and design of fly ash and bed ash silo for thermal power plant structures], international journal of engineering sciences & research technology, issn:

2277-9655, impact factor: 4.116, coden: ijess7,
2017.

Cite this article as :

Mukesh Kumar, Rachana M Bajaj, Kapil Soni,
"Analysis of a Cement Storage bin Considering Lateral
Forces using Staad.pro", International Journal of
Scientific Research in Civil Engineering (IJSRCE),
ISSN : 2456-6667, Volume 4 Issue 4, pp. 91-96, July-
August 2020.

URL : <http://ijsrce.com/IJSRCE204413>